



***International  
Competition Rules***

for

**JUNIOR FIREFIGHTERS**

6<sup>th</sup> Edition 2004

Published by the  
International Committee of Instructors of Junior Firefighters of the CTIF

## **Table of Contents**

### **(A) GENERAL CONDITIONS**

#### **1. Events, team composition, age limit, words of command**

- 1.1 Events
- 1.2 Team composition
- 1.3 Age limit
- 1.4 Words of command

#### **2. Competition directorship and judges' tasks**

- 2.1 Conduct of competitions
- 2.2 Judges tasks

#### **3. Competition field**

### **(B) DESCRIPTION OF EVENTS**

#### **1. Fire Fighting Obstacle Competition**

- 1.1 Competition track
- 1.2 Clothing and personal equipment
- 1.3 Conduct of the competitions
- 1.4 Sketches of obstacles for fire fighting obstacle competition
- 1.5 Sketch of the track for fire fighting obstacle competition
- 1.6 Pictures of knots
- 1.7 Apparatus for the competition
- 1.8 Scoring

#### **2. Sports competition**

- 2.1 The 400 metre race with obstacles
- 2.2 Clothing and personal equipment
- 2.3 Conduct of the event
- 2.4 Scoring

**(C) CONDUCT OF THE COMPETITIONS AND JUDGES**

**1. Registration and reporting for the competition**

- 1.1 Registration
- 1.2 Reporting for the competition

**2. Judges**

- 2.1 Fire fighting obstacle competition
- 2.2 Sports competition

**(D) RESULTS**

**(E) CONCLUSION**

Annex: Copy of the registration and score sheet

## **COMPETITION RULES**

### **(A) GENERAL CONDITIONS**

#### **1. Events, team composition, age limit, words of command**

##### **1.1 Events**

1.1.1 For the International Youth Fire Brigades Competitions these rules have been published by the Technical Section of the CTIF.

1.1.2 The teams who report to the International Junior Firefighter Competition must compete in the fire fighting obstacle competition as well as in the sports competition, in accordance with the applicable competition rules.

##### **1.2 Team Composition**

1.2.1 The team composition for both events is 1:8 plus 1 firefighter in reserve (i.e. 10 firefighters).

##### **1.3 Age limit**

1.3.1 The age limits for competitors are between 12-16 years old.

1.3.2 To participate in the International Junior Firefighter Competition, the calendar year during which the competitor reaches 12 or 16 years respectively is applicable. Details with indication of dates of birth shall be given at the time of publication of the registrations for the competition.

##### **1.4 Orders and words of command**

1.4.1 Orders and commands may be given in the national language and in the usual forms used in each country.

1.4.2 The starting signal for an event is a whistle blast.

## **2. Competition Directorship and judges' tasks**

### **2.1 Competition Directorship**

- 2.1.1. The Competition Director shall preside over the team of competition judges and is responsible for the smooth running of the competition. Interpreters shall be seconded to him to assist him in his task.
- 2.1.2 In case of disagreement regarding scoring, the Competition Director shall decide and his decision shall be final. Video recordings will not be allowed to settle disputes.
- 2.1.3 The team of judges shall be composed of members of fire services of all the nations participating in the international competitions for junior fire fighting teams. The number of judges shall depend on the number of teams' registered. The judges shall be appointed by the Competition Committee.
- 2.1.4 The team of marshals shall be provided by the host country. This team shall be under the control of the Competition Director and shall be responsible for arrangements on the competition field.
- 2.1.5 When it is found that there is a technical defect in an apparatus, the Competition Director, on the advice of the judges, may decide the event should be performed again. This provision also applies to the sports competition. The Competition Director, on the advice of the judges, may decide to replace any equipment.

### **2.2 Tasks of the judges**

- 2.2.1 The adjudicators shall be located on the competition field; they shall check the competing teams prior to their participation in each event, hand over an envelope with score sheets and ensure the smooth running of the

competition. They shall calculate the final result after receiving the score sheets and shall complete the competition certificates.

2.2.2 The judges for the fire fighting obstacle competition shall score the competition according to the rules and enter the results into the score sheets.

2.2.3 The judges for the sports competition shall score the relay race according to the rules and enter the results into the score sheets.

2.2.4 The judges shall not judge a team of their own nationality.

### **3. The competition field**

#### **3.1 The competition field**

The competition tracks for the fire fighting obstacle competition and for the sports competition must be set up on the day prior to the practice run in order to enable the judges as well as the Competition Director to make any changes or additions that may be required to the basic standards.

When appropriate, the Competition Director as well as the judges shall notify the team leaders and the instructors of any changes before the beginning of the practice.

3.1.1 The number of competition tracks for the fire fighting obstacle competition shall depend on the number of competing teams and shall be fixed by the Competition Committee. The track for the fire fighting obstacle competition shall be 75m in length. The assembly point before the start line shall be 5m (lane width) wide and at least 3m deep.

3.1.2 The number of lanes for the sports competition shall

depend on the number of teams registered and shall be fixed by the Competition Committee. The relay race tracks shall be 400m in length.

## **(B) DESCRIPTION OF THE EVENTS**

### **1. Fire Fighting Obstacle Competition**

#### **1.1 Competition track**

1.1.1 Track section 1: from the start line to the 60 metre mark.  
In this section, 4 obstacles shall be situated in the centre of the track respectively at right angles to the direction of the race (ditch and hedge), and parallel in the direction of the race (crawling tunnel and balancing beam).

1. Ditch:

Width: 1.80m, length 2m, near the 8m mark;

2. Hedge:

Height: 0.70m, width 2m, near the 23m mark;

3. Crawling Tunnel:

Length: 6m, width 0.60m, height 0.80m, (hanging roof), near the 38m mark;

4. Balancing Beam:

Length: 2m, 0.35m above ground (upper side), 0.20m wide, near the 53m mark.

In the middle of the start line a fixed 65mm C-coupling shall be placed. To its left, there shall be placed 4 Dutch-rolled 45mm hoses with straps. Hoses will be placed in front of the start line with the couplings facing forwards. Hoses will be spaced about one hose width apart.

1.1.2 Track Section 2: from the 60m mark to the 65m mark.

Two stirrup pumps each containing 10 litres of water

shall be placed at the 60m mark 1m in from the left and right edges of the competition lane. The 15mm hose connected to each stirrup pump is 3m long and is provided with a nozzle of 4mm diameter maximum. The hose is Dutch-rolled and is to be completely stowed in the hose bracket on the pump (except for the section of hose to which the branch is fixed), the branch being placed on the lid of the stirrup pump with the nozzle facing forward (toward the target).

The target wall with a hole 10cm in diameter shall be placed near the 65m mark. In front of that wall, a red batten shall be placed 2m before the 65m mark.

Fixed to the back of the target wall, there shall be a container of about 6 litres capacity.

By means of a float, an acoustic signal and an optical signal shall be activated simultaneously as soon as the container is filled with 5litres of water. A bucket containing 10 litres of water shall be placed to the left (and right) of the competition track near the stirrup pumps.

#### 1.1.3 Track section 3: from the 65m mark to the 70m mark.

A frame for knots with 4 interchangeable diagrams showing;

- a clove hitch,
- a branch fixed with the line by a half hitch,
- a timber hitch; and,
- a reef-knot.

Four lines, 3 of which are 2m in length, 8mm in diameter and a standard line for fixing the branch, 12mm in diameter in it's bag, are suspended from the frame, in front of which is situated a branch coupled to a Dutch-rolled 45mm hose. The 4 work stations under the diagrams are marked No 6, 7, 8 and 9 (see sketch 1.6). The diagrams must be interchangeable. The

frame shall be 1m in height 2m in width, sited at the 70m mark and set up on the right edge of the competition track. On the left edge of the competition track at the 70m mark, a frame shall be set up with 8 revolving diagrams of equipment and small gear with photographs on each side. The diagrams represent;

1 dividing breeching	1 hose strap
1x 15mm (C size) branch	1 bucket
1 length 45mm hose	1 coupling key
1 collecting breeching	1 suction strainer

These items of equipment are laid out in order and placed in front of the frame along the left edge of the competition track. The items of equipment corresponding to the photographs are placed in the spaces numbered 2, 3, 4 and 5. (see sketch 1.4).

1.1.4 Track section 4: from the 70m mark to the 75m mark.  
Assembly point for the teams at the end of the competition.

## 1.2 Clothing and personal equipment

1.2.1 The teams shall report in their national fire fighting uniform (working uniform). Gloves and fireman's belts are permitted provided the whole team are dressed the same; i.e. all wearing the same pattern gloves, belts etc.

1.2.2 The choice of shoes is the decision of the team, but all team members should, as far as possible, wear shoes of the same colour. Running shoes (spikes) and shoes with studs are not permitted.

1.2.3 The teams shall report with their national pattern of fire helmet.

### 1.3 Conduct of the competition

1.3.1 The team of 9 junior fire-fighters shall report for assembly at the start line in two ranks. The team members shall wear on the chest and back the numbers 1 to 9 in a clearly visible manner.

The No 1 shall be of white material and shall be that of the leader of the team. The material for No 2 to 5 shall be red; and from 6 to 9 the material shall be yellow. The members of the team shall be numbered as decided by the team leader. After the team is presented by the leader with the words "Team assembled for the competition", the principal judge shall give the command "Start". The team leader shall then lead his team with the words "right right", the team facing the start line in two columns. The team leader or the principal judge shall then give the order "Attack!" with a whistle. The whistle blast shall start the stopwatches of the judges.

The electronic chronometer may be started by the principal judge by means of an acoustic signal.

1.3.2 After the order "Attack!" is given, the leader shall tackle the obstacles and go to the 65metre mark where he takes his position between the target walls. From that spot, he shall monitor the operations of the 1<sup>st</sup> team who, by means of the stirrup pump, shall direct water through the hole into the reservoir mounted behind the target wall. Junior fire-fighters No 2 to 5 shall proceed in order through or under the obstacles of the 1<sup>st</sup> section towards the stirrup pumps placed in the 2nd section. (Note: for the purposes of risk assessment, competitors may jump, step on or straddle the hurdle).

1.3.3 No 6 to 9 shall then pull a line of hose respectively under, over or through the obstacles of the first section. No 6 shall begin by entering the competition lane (note:

at least one foot must remain in the lane) taking one of the 4 x 45mm lengths, running it out (unrolling it) and coupling it to the fixed coupling on the start line.

No 7 shall take a second hose length and one of the ends of the 1<sup>st</sup> (Number 6's) which he shall draw over the ditch, towards the 60m mark. It should be noted that the obstacle, i.e. the ditch, must be jumped over correctly. When the first length is run out he shall run out (unroll) the 2nd and couple one of the ends to that of the 1<sup>st</sup> hose. No 8 shall also take a length and jump correctly over the ditch until he reaches the hose of No 7, taking one of the ends of the hose run out (unrolled) by Number 7 and go towards the 60m mark. Near the 23m mark, he shall pass the hose being run out under the hedge. He shall himself cross over the hedge with the hose which is still made up. The hose must not be thrown to the other side of the obstacle. When the firefighter has run out the hose, he runs out (unrolls) the one he has brought over and couples one of its ends to the laid out length.

No 9 shall also take a hose length and cross correctly the obstacles until he reaches No 8's laid out hose.

He shall then take the end of the hose run out by Number 8 and pull the hose through the crawling tunnel towards the 60m mark. When he has fully run out the hose, he shall run out (unroll) the one he has brought and couple one of the ends to the laid out hose. The hose strap is not to be opened before the hose is completely run out. It is not regarded as a mistake that two junior fire-fighters couple the hoses together in the following order: 7/8, 8/9, 9/6. There is no penalty if the hoses are run out (unrolled) before they are connected. After he has coupled his hose to the, fixed coupling, No 6 must go through the obstacles

with his strap until he reaches the hose laid out by No 9. He shall then take the end of the laid out hose and, whilst crossing the balance beam, place it to the right of and next to the balancing beam, it being understood that he must cross this correctly as far as the 60m mark: the hose is to be pulled straight to reach at least 59 m. All four competitors must correctly cross the 4 obstacles and place the straps in the box placed near the 58m mark. It is not a penalty if No 6 pulls the hose and puts his hose strap in the box, or puts his strap in the box then pulls the hose straight.

- 1.3.4 No 2 and 3 shall, after they have gone through the first section, go to the stirrup pump placed to the left of the competition track. No 2 shall now take the branch and go forward to the red marker but he shall not touch it. No 3 shall take the handle of the stirrup pump and operate it. No 2 who carries the branch shall then try as quickly as possible to direct 5 litres of water through the hole of the target wall. Acoustic and optical signals shall indicate the end of the operation. If it is not possible to fulfil the task with the 10 litres of water held in the stirrup pump No 3 must refill the stirrup pump with the water reserves placed near-by. The Number 3 may not give the branch to Number 2.

The same exercise must be carried out by No's 4 (2) and 5 (3) with the stirrup pump placed to the right of the competition track.

- 1.3.5 The judge for the equipment test can set 4 out of the 8 diagrams on the corresponding frame. Once done this must be indicated at the beginning of each heat by a hand signal to the principal judge.

After they have completed their mission on track section No 2. No's 2 to 5 must, after having received their respective acoustic and optical signal, run

towards the equipment frame and place next to their allocated number the items corresponding to the indicated diagram. The items of equipment are placed in front of the frame at the left edge of the lane. The equipment is placed in the appropriate space and mat not be moved. The 4 competitors must then cross beyond the 70m mark and assemble in the track section No. 4.

The team leader shall only go forward with Numbers 2 and 3 once they have completed their pumping. (Even if 4 and 5 finish first).

- 1.3.6 The judge for the knots test can modify at each heat the 3 interchangeable diagrams. Number 7 will only tie the hose and branch knot. Before each heat, he shall indicate by hand signal to the principal judge that no further modification may be made (after the hand signal no modification may be made to either the equipment frame or to the frame for knots).
- 1.3.7 When the hose line is fully laid out, Nos 6 to 9 must go to the frame for knots near the 70m mark. The competitors must run in the centre of the lane between pumps and target walls to the Knot frame. In that frame above their number, there is a diagram of the knot, they must make on the frame. The knots are to be executed in accordance with diagram 1.6 in the competition rules. The clove hitch and the timber hitch are to be made on the knot beam. The branch and hose together with completed full and half hitches must not be hung over the beam but may be placed on the ground. It makes no difference whether the line bag is at the nozzle or hose end of the line. The hose knots are to be completed only by team member No. 7.

When they have carried out that task, they shall cross

beyond the 70m mark and assemble in section No 4.

1.3.8 When all the exercises are completed, the whole team including the leader shall go to the finish point. When the team is assembled in two ranks (facing the start line), the team leader raises his right hand to signal to the principal judge "Competition concluded". When the time keepers record that the team has completed its exercises and is fully assembled, the two judges shall stop the timing.

1.3.9 The team leader's task is to supervise the competition, but he is not authorised to give directions while the competition is in progress; it is forbidden to speak during the competition. After the competition, the team leader shall present the team to the principal judge.

#### 1.4 Sketch of obstacles for the firefighting obstacle competition

(All measurements in cm)

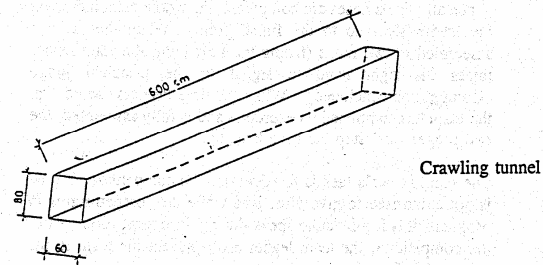
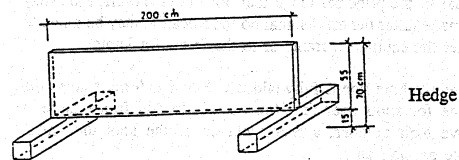

1.4 Sketch of the obstacles for the fire-fighting obstacle competition

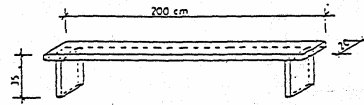

Balancing beam

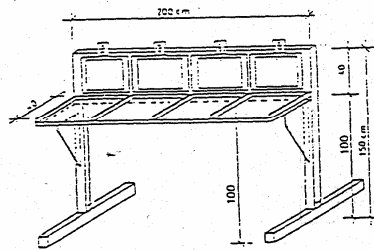

Equipment frame with  
interchangeable diagrams

All measurements in cm

- 1.4 Sketch of the obstacles for the firefighting competition  
Target wall showing container, float, optical and acoustic signals

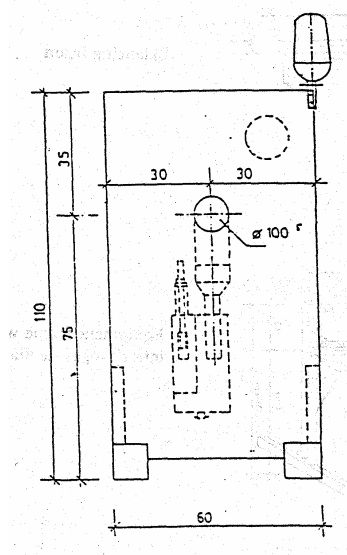

All measurements in cm.

- 1.4 Sketch of obstacles for the firefighting obstacle competition.  
Target wall showing container, float, optical and acoustic signals.

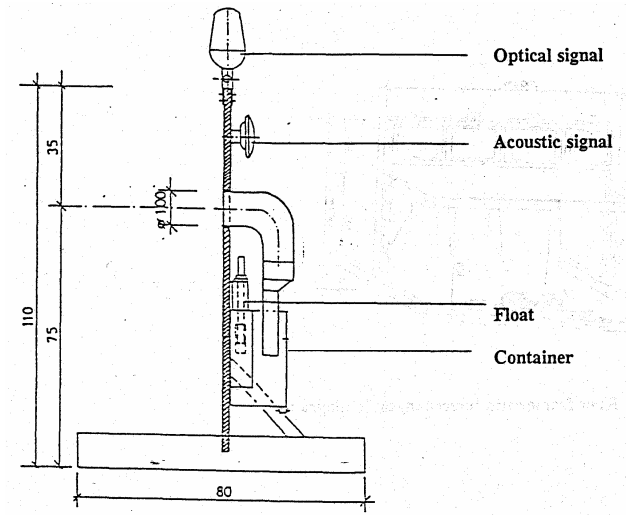

- 1.4 Sketch of the obstacles for the fire fighting obstacle competition

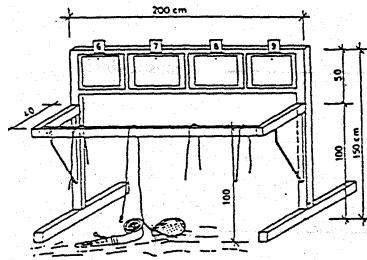

Knot frame with interchangeable diagrams

All measurements in cm

1.5 Sketch of the track for the fire fighting  
obstacle  
competition

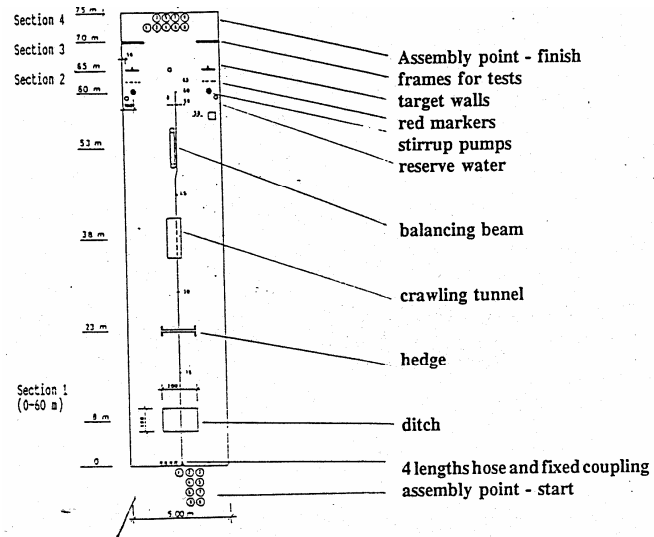

1.6 Sketch of knots

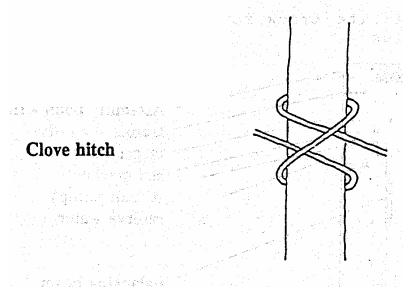

### 1.7 Sketch of knots

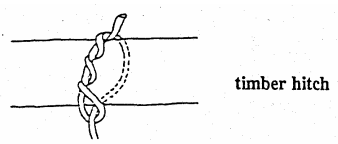
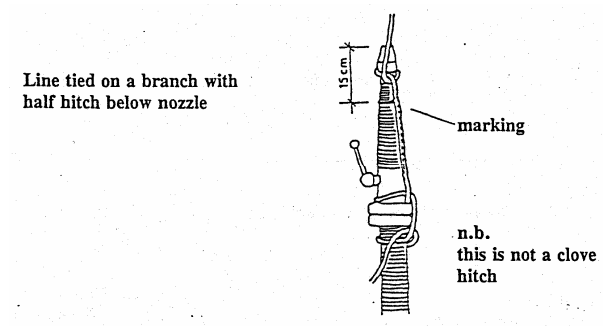

## **1.7 Competition materials and equipment**

- 1.7.1. The host country shall provide the obstacles as are defined under 1.4 and shall build the competition track or tracks in accordance with sketch 1.5.
- 1.7.2 The technical equipment needed for the fire fighting obstacle competition shall be provided by the host country.
- 1.7.3 Training for the fire fighting obstacle competition shall be carried out with the equipment provided by the host country.

## **1.8 Scoring**

- 1.8.1 Each competing team shall receive 1000 starting points.

From these start points the finish time in seconds and tenths of seconds; and any penalty points, will be deducted.

In the obstacle competition each point deducted for a mistake equates to one second. E.g. 5 penalty points = 5 seconds deducted.

### **1.8.2 Penalties**

- Mistakes on the obstacle course -10 points  
In Section I of the obstacle course for each obstacle passed incorrectly 10 penalty points will be awarded.

- Complete twisting of hose – 5 points

If a hose has a complete twist, 5 penalty points will be awarded. Each length of hose will be judged separately, however the maximum penalty will be one twist per length.

- Opening of a coupling – 20 points

The opening of couplings will be judged, if after the obstacles have been passed a pair of couplings has not been made correctly in accordance with the regulations.

- Wrong layout of 45mm hose in the 1st section - 10 points

If the hose is not laid out correctly in Section I a penalty will be awarded. The hose must be laid out to at least the 59 metre mark.

- Left or forgotten equipment – 5 points

Helmets count as equipment as do hose straps. Left or forgotten hose straps will be penalised if the hose strap is not placed in the strap box.

- Wrong item at the equipment frame – 10 points

A competitor will be penalised if a piece of equipment is not placed at the place corresponding to their number and the picture.

- Knot wrongly made - 10 points

Wrongly made knots will be penalised if the knot does not correspond to the picture or is incorrectly made.

- Incorrect working – 10 points

“Incorrect work” will be penalised, if an activity is not carried out correctly by a competitor, according to these rules.

This will not apply if the work is carried out by another competitor (i.e. no double penalty).

Should a mistake have been made by a competitor

due to an unforeseen or questionable action, an “incorrect work” penalty will be awarded.

If a coupling should open which cannot be attributed to a particular competitor, the open coupling penalty will apply.

If the group leader gives the “finish” hand signal early or late he will be penalised.

This list of “Incorrect work” is not exhaustive.

- Speaking during the Competition

each mistake - 10 points

Speaking during the competition will be judged on each different competitor who speaks. Each judge will indicate each infringement. The Head judge considers each mistake and enters them on the judging sheet.

- Leaving the Lane each mistake – 10 points

Competitors stepping out of the lane with both feet will be penalised. (Once the lane has been entered competitors will not leave until released by the Head judge after their exercise has been completed and debriefed, where necessary).

## 2. Sports Competition 400m relay, race with obstacles

### 2.1 Relay course and construction of obstacles.

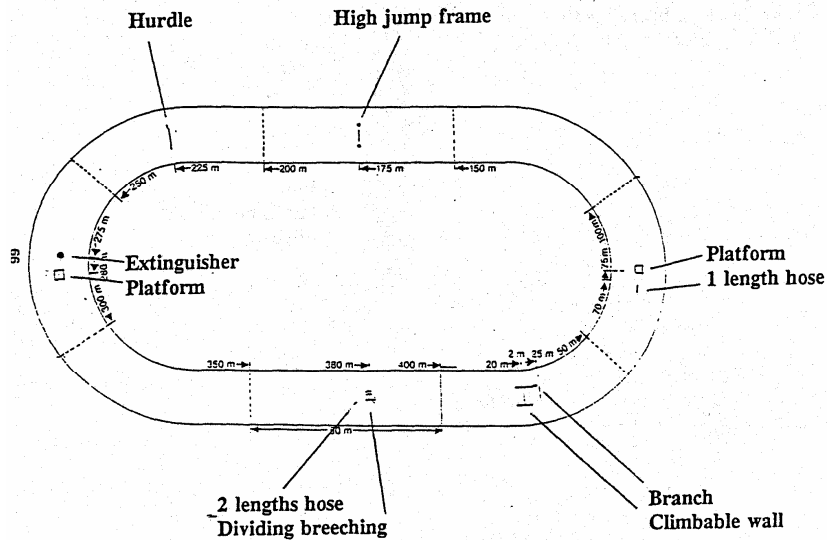

Hand over markings are to be made in Section 2 at the 37.5m mark; Section 4 at the 125m mark; Section 7 at the 325m mark and Section 9 at the 365 m mark.

2.1.1 The track for the relay race is 400m long and is divided into 9 sections. The Relay race line is define as from the Start to the Finish line. A lane is of minimum width 1.2m.

2.1.2 The baton is a branch of 45mm diameter.

2.1.3 Construction of obstacles.

1. Section 1: at the 20m mark is a climbable wall;2m high and 1.2m wide, with 4 horizontal bars. A 45mm branch is placed at the left hand side after the wall, in the direction of travel. (Inside the lane edge marking).
2. Section 2: is a running section, without an obstacle.
3. Section 3: at the 70m mark placed in the lane there is a 45mm hose, Dutch-rolled and secured with a strap. Couplings facing forward.  
Placed 5 metres on from the hose is a stable wooden platform, 0.03m high by 0.8m x 0.8m. This platform is for laying the hose on and is sited in the middle of the lane.
4. Section 4: is a running section without an obstacle.
5. Section 5:-at the 175m mark there is a jump 1.2m wide, resembling those used in high jump events, with a rod across it at 80cm height.
6. Section 6: at the 225m mark there is a hurdle 0.6m high, as used in hurdle races.
7. Section 7: at the 275m mark there is an empty extinguisher weighing 6 kg, 5 metres. further on in the lane there is a wooden platform in the middle of the lane 0.03m high by 0.8m x 0.8m. This is for placing the extinguisher on.
8. Section 8: is a running section, without an obstacle.
9. Section 9: at the 380m mark there are 2 made-up lengths of 45mm hose, with couplings but without

straps. The couplings are to sit on top of each other facing forward. On the right in the direction of travel there is a dividing breeching.

2.1.4 The relay race takes place in 2 adjoining lanes. All 9 members of a team must each overcome an obstacle and run one section of the course. Competitors in the relay race must be the same ones who take part in the fire-fighting obstacle race.

The team leader is responsible for allocating team positions.

2.1.5 Positions for competitors.

Number 1 :	behind the start line
Number 2 :	at the 25m mark
Number 3 :	at the 50m mark
Number 4 :	at the 100m mark
Number 5 :	at the 150m mark
Number 6 :	at the 200m mark
Number 7 :	at the 250m mark
Number 8 :	at the 300m mark
Number 9 :	at the 350m mark

Handover of the branch must take place at each of the designated marks. In sections 2, 4 and 8 the baton must be handed over in the first half of the section.

This is in;

Section 2 – at the 37.5m mark;

Section 4 – at the 125m mark;

Section 8 – at the 325m mark.

In section 9 the baton must be handed over in the first 15m (i.e. before the 365m mark). In the event of non-compliance rule 2.4.1 will apply and a 10 second time penalty shall be incurred for each infringement, but the next competitor is not penalised if he starts to run before the branch is handed over. The competitor who

has handed over the branch must leave the track immediately, and in such a fashion that he does not impede the competitor in the next lane.

- 2.1.6 Runner Number 1 starts the race without the branch when the starting signal is given. The other runners take the branch on handover and can carry it in any way they wish, but not in **the mouth, and must cross the obstacle with** the branch (this does not apply to Section 1).

## 2.2 Clothing

Teams must report in their national pattern of fire gear, with solid shoes. Studs or running spikes are not allowed.

## 2.3 Conduct of the event

- 2.3.1 The relay race takes place as follows:

1. Section 1: Competitor Number 1 starts to run when the starting signal is given. At the 20m mark he must cross the barred wall. He must touch the 3rd and 4th bars with his hands and the 1<sup>st</sup> and 2<sup>nd</sup> bars with his feet. This applies to both the climb and the descent. He must pick up the branch at the left side after the wall (in the direction of travel) and pass it to Number 2 after running the second half.
2. Section 2: In the first half, before the 37.5m mark the Number 1 must pass the branch to Number 2.
3. Section 3: Number 3 takes the branch from Number 2, picks up the Dutch-rolled hose at the 70m mark and puts it on the platform sited 5m further on. The hose must not be left outside the

edges of the platform. It is not a penalty if part of the strap overhangs the board. When this exercise has been completed, Number 3 passes the branch to Number 4 after the 100m mark.

4. Section 4: In the first half of Section 4 before the 125m mark Number 3 must pass the branch to Number 4.
5. Section 5: Number 5 takes the branch from Number 4 and must pass under the obstacle without knocking the rod down. If the rod falls, he may replace it on the supports and, carry out the exercise again, but he must not leave the lane.
6. Section 6: Number 6 takes the branch and must jump over the hurdle. If the hurdle is knocked over he may replace it and jump it again, but must not leave the lane.
7. Section 7: When Number 7 has received the branch from Number 6 he runs to the extinguisher, picks it up and places it on the marked spot. If the extinguisher falls over before Number 7 hands the branch to Number 8 he may replace it. However, if he fails to replace it he will be judged to have contravened the rules and be penalised 10 seconds.  
Note; If the extinguisher falls after the hand over to Number 8, no penalty will be called.
8. Section 8: Number 7 must pass the branch to Number 8 in the first half of the Section before the 325m mark.
9. Section 9: Number 8 must pass the branch to Number 9 before the 365m mark. The Number 9 runs to the hose lengths, couples them together and connects one end to the dividing breeching. The branch is connected to the free end of the

second length. The couplings must be connected by both lugs and not broken again during the exercise. The competitor crosses the finishing line with the branch connected and places it on the ground. The coupling must go over the finishing line. The branch must not be uncoupled.

Once the race has begun, should the hose or couplings accidentally move the Number 9 may not leave the 350m mark to correct them. This will not be penalised. Number 9 is to ensure that the branch is coupled to the hose before crossing the finish line (the branch must be securely attached to the hose).

- 2.3.2 The branch may not be carried in the mouth; it must be passed from hand to hand. If a competitor does not cross an obstacle in accordance with the rules he has the right to tackle the obstacle again.
- 2.3.3 The event is considered as finished when the competitor in section 9, crosses the finishing line.
- 2.3.4 Each competitor designated by the team leader to tackle an obstacle must cross the obstacle in accordance with the rules before passing on the branch. The extinguisher and the hose may not be touched when the event is finished.

## 2.4 Scoring

- 2.4.1 Each team is allocated, according to its average age, a base time and an initial score of 100 points.

Total Age	Average A	Base Time
Up to 112	12	80 secs
113-121	13	77 secs
122-130	14	74 secs
131-139	15	71 secs

140-144

16

68 secs

Penalties:

Open coupling, each case, 10 points.

Obstacles not crossed, or task not completed in accordance with the rules, each case, 10 seconds.

For each second under the base time, measured at the finishing line, an extra point is awarded.

For each second over the base time a point is deducted.

For each incorrect changeover 10 points will be deducted.

Having both feet outside the lane on the relay will be judged in the same way as failure to tackle an obstacle correctly or failure to complete a task and a penalty of 10 points incurred.

If any mistakes are made during the relay the judges may not touch anything. Instead they are to call the runner over and point out the mistake at the completion of the event. The judges are not to give any instructions to competitors.

Video evidence will not be allowed to appeal against any decisions.

2.4.2 A team competing in the 400m event may be disqualified for the following faults:

- q Runner not completing a section
- q After three false starts
- q Last competitor not crossing the finishing line
- q Branch not crossing the finishing line
- q Branch not passed from one runner to the next

- q A runner leaving his lane and impeding another

2.4.3 The time measured is from the starting signal for the first runner till the last runner crosses the finishing line. The time is measured in seconds and hundredths of a second.

## **(C) CONDUCT AND JUDGING OF THE COMPETITION**

### **1. Arrival and registration at the competition**

#### **1.1 The Registration**

On arrival of the teams at the competition site, their officers in charge will report to the junior fire-fighter competition office to register the teams. They will receive all necessary documentation.

#### **1.2 Reporting for Competition**

Teams must report to the timekeeper's office half an hour before the scheduled start of their events. At this time they must hand over their finalised team list and collect the envelope containing their score sheets.

### **2. Judges**

#### **2.1 Fire-fighting obstacle competition**

2.1.1 The competition will take place under the supervision of a presiding judge.

2.1.2 Requirements for judges and timekeepers:

- (a) at the start and finish: judge Number 1 supervises the ditch and hedge in Section 1, and also the laying out of the 45mm hose. At the same time he operates stopwatch No. 1.
- (b) judge Number 2 supervises the crawling tunnel

and balancing beam in Section 1, and also the laying out of the 45 mm hose; and the hose strap box. At the same time he operates stopwatch No. 2.

- (c) judge Number 3 supervises Section 2, in particular the use of both stirrup pumps which he checks are full and whether the team leader takes up position at his observation point and that he leaves it with competitors 2 and 3.
- (d) judge No. 4 supervises the equipment test in section 3.
- (e) judge Number 5 supervises the knot test in Section 3.
- (f) each judge only supervises his own section.

the principal judge takes overall charge of timekeeping and supervises all the sections. He enters the times and penalties on the score sheet.

Scoring will be done by consultation with the other Judges responsible for their sections and the Group leader to avoid differing scores. If a mistake is suspected with any equipment it is not to be touched by any judge. It will be shown to and explained to the Group leader.

Where electronic timekeeping is available it will be started and stopped by the principal judge. The time will be recorded in seconds and tenths of a second.

## **2.2 Sports Completion**

2.2.1 1 judge and 2 timekeepers are required for each lane.

- (a) The judge has overall supervision of the lanes and

is the starter.

(b) 2 timekeepers per lane.

2.2.2 The official time for the event is the average time between the two stopwatches. Electronic timekeeping may be used but does not dispense with the need for timekeepers. Electronic time keeping will be taken in seconds and hundredths of a second.

## **D FINAL RESULTS AND THE JUNIOR FIREFIGHTER COMPETITION BADGE**

### **1. Results**

The points gained in both the fire-fighting obstacle race and the relay race are taken into account when deciding the final results. The results are based on the total number of points gained.

Example: Fire-fighting obstacle race	900.0 points
Relay Race	<u>+ 90.00 points</u>

Total 990.00 points

### **Results in the event of a tie**

In the event of two or more teams scoring the same number of points, the following criteria will be applied in order, so that final placings may be decided.

1. Fire-fighting competition completed without faults.

2. Fire-fighting competition completed without faults in the best time
3. Fire-fighting competition completed with least number of penalty points.
4. Best time in the relay race

If after the application of these criteria final placings still cannot be decided, a tie will be declared.

## **2. Junior Fire-fighter Competition Badge**

The international badge of the Junior Fire-fighter Competition will be distributed to participating teams at the closing ceremony, assuming that there has been no disqualification.

## **E CONCLUSION**

The provisions of these rules were adopted by the CTIF's Junior Fire-fighter Committee at their meeting of 22 May 1976 at Melun in France.

The Permanent Council of the CTIF at its meeting in Berlin on 17 June 1976 ratified the provisions of these rules. Amendments to the rules were made on future occasions.

